



DYCON
power solutions

Dycon D1460

12V 2A Power Supply

**Technical Description
Installation and Operating Manual**



DYCON POWER SOLUTIONS LTD

Tel: +44 (0)1443 471 900

Unit A Cwm Cynon Business Park – Mountain Ash – CF45 4ER - UK

www.dyconpower.com - sales@dyconpower.com

D1460 12V 10A SWITCHED OUTPUT PSU

MANUAL

Overview

The power supply is designed around Dycon's battery management and system monitoring technology for access control applications.

An outline block diagram is shown below: -

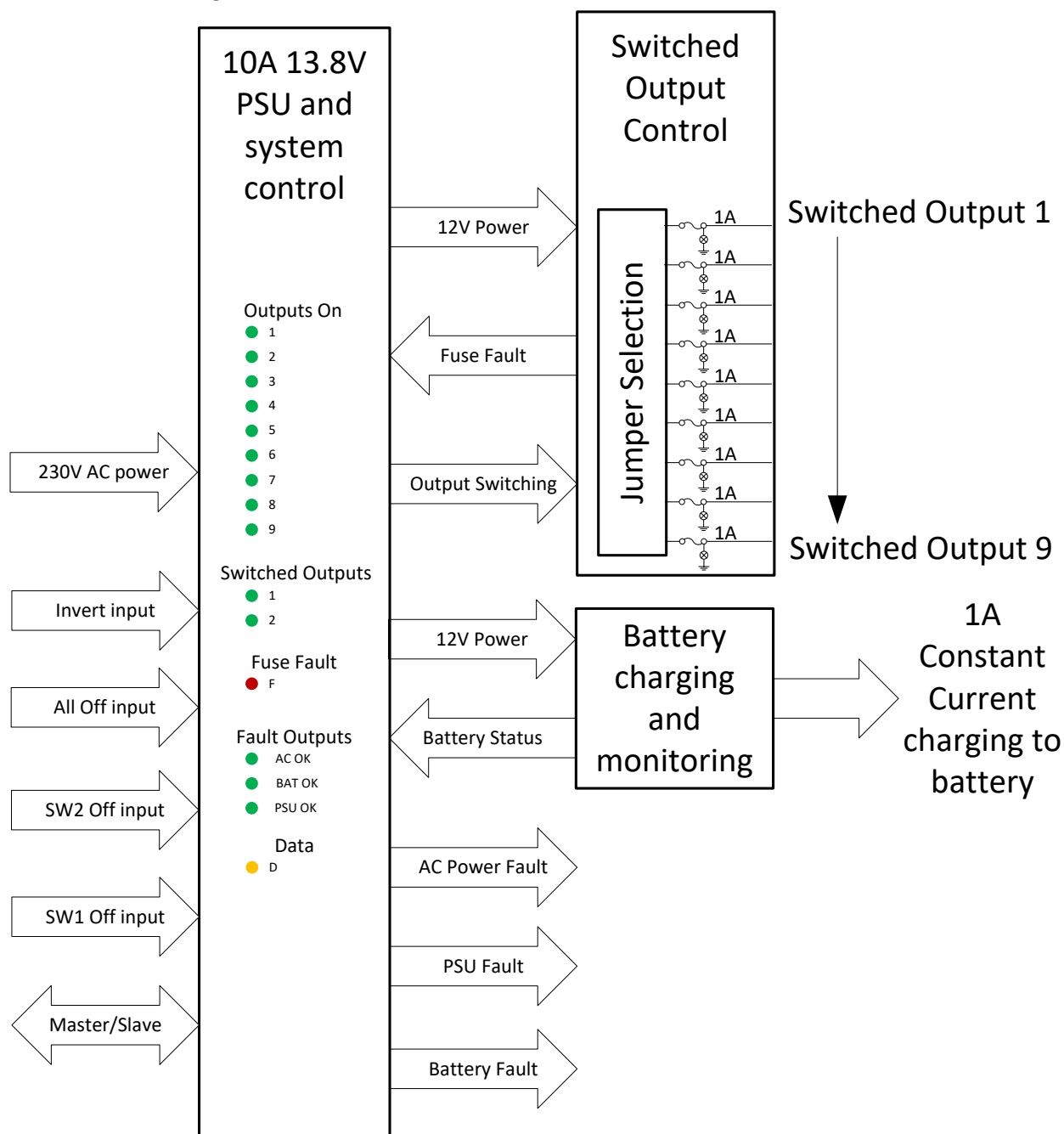

Feature List

- 9A maximum output
- 1A constant current battery charging
- 9 switched 1A outputs protected by PTC resettable fuses with fuse monitoring
- Individual output switching selected by jumper link
- Outputs can be divided into two separate switched groups and an always-on group
- Group switching by applying a positive voltage to three control inputs
- Group 1 and group 2 can be switched individually with an all groups switched-off override
- All outputs protected from inductive load transients
- Current limited 1A constant current battery charging
- Fully protected battery charging circuit
- Battery health impedance testing
- Battery presence detection
- PSU operation and status monitoring
- Over-voltage shutdown protection
- Individual PSU fault, Battery fault and AC power fault outputs
- On board 16-LED status display
- Master/Slave ganging to allow connection of two PSUs together, to operate as a single PSU
- Outputs can be connected in parallel for higher current loads
- External LED \OK indicator

Electrical Specifications

SPECIFICATIONS	
AC Input Voltage	230VAC \pm 10%, 50Hz.
SMPS PSU protection	Hysteric over-temperature and over-voltage protection
Maximum Input Continuous Current	1A
Peak inrush current limit	20A maximum.
Recommended Switched Spur Input Fuses	250V T3.15A 1.5KA breaking
Voltage Output AC Present	Minimum 13Vdc, Maximum 13.9Vdc, Load Dependant
Voltage Output Standby	Minimum 10Vdc, 12 V Nominal, Load Dependant
Total current output	10A continuous, 12A peak for 10 minutes
Current output with battery charging	9A
Battery Charging Current	Constant current, low impedance, 1A minimum
Low Voltage detection thresholds	<11V \pm 2%, low voltage restore, >11.5V \pm 2%.
Battery Fault Circuit Impedance Threshold	>0.18 Ohm \pm 5%, at a nominal test current of 5A.
Deep Discharge Disconnection Threshold	<10.5V \pm 2%.
Overvoltage Detection Shutdown Threshold	>15V \pm 2%.
Output Monitoring Threshold	Battery charging voltage <2V \pm 2%.

SPECIFICATIONS	
On-Board AC Power Input Fuse	1A timed, 1.5KA breaking, ceramic
Battery Fuse	PTC, self-resetting, non-replaceable
Switched Output Fuses 1 to 9	1.1A PTC, self-resetting, non-replaceable
SW1, SW2, ALL Control Inputs	Logical 0 <1V, Logical 1 >4V, 30V tolerant, 100K pull-down
Fault Relays	Normally closed, 100mA at 60V. On-Resistance 16 ohms maximum, 1500VRMS Isolation voltage
Battery current drawn by power supply without AC supply	Maximum 90mA (Depending on PSU status)
Maximum Ripple Voltage	0.7V peak to peak.
Battery Type	Sealed Lead Acid Gel, 12V, 24AH maximum for 24 hour charging
Operating Temperature and Humidity Range	-10°C to +40°C, 95% maximum humidity, non-condensing
PCB Footprint Dimensions	170mm X 157mm

PCB Layout

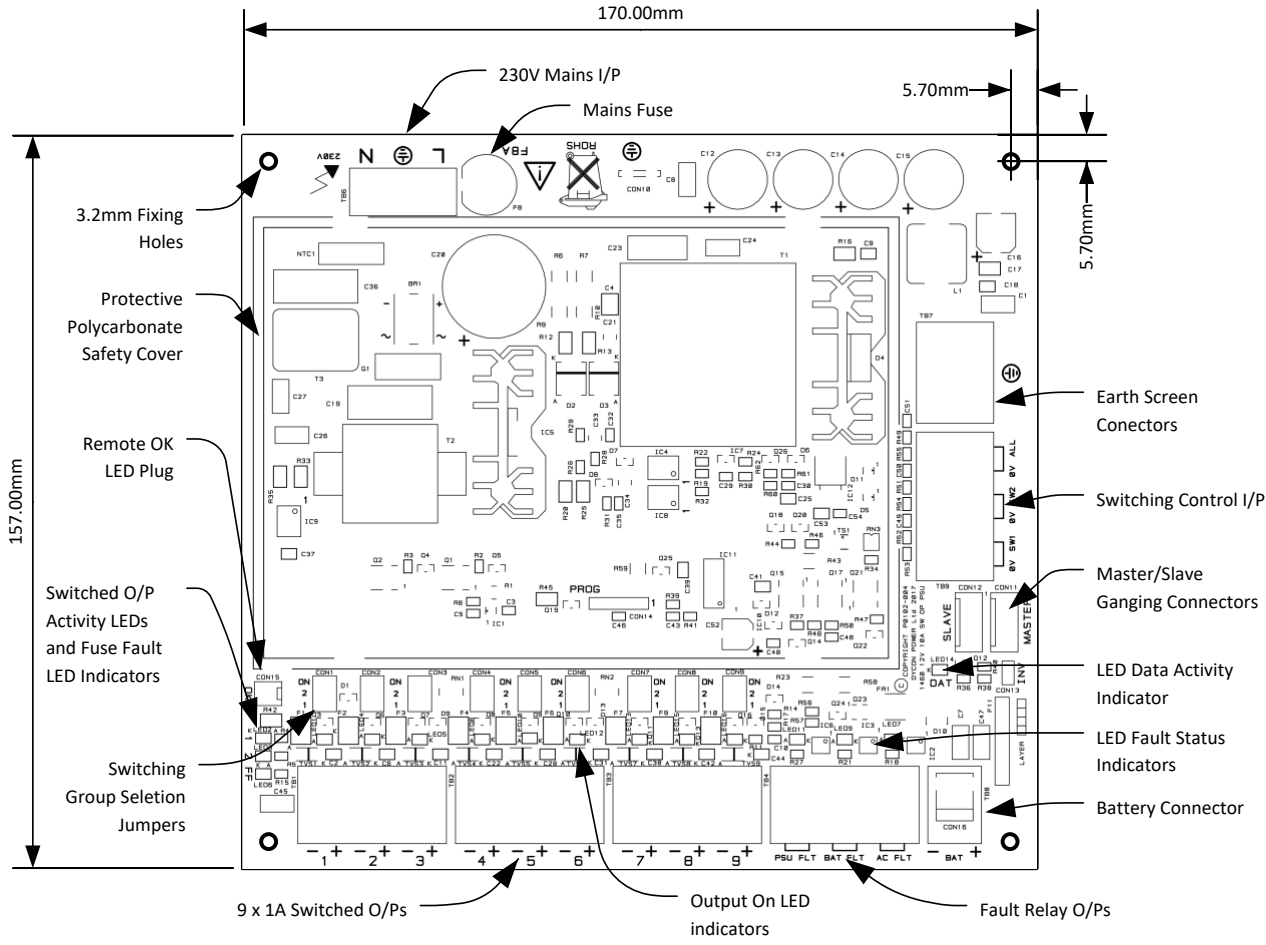

Outputs

There are three 6-way, pluggable 45° terminal blocks for connecting the PSU.

The outputs are short-circuit protected with 1.1A Positive Temperature Characteristic (PTC) non-replaceable fuses. The outputs can either be switched on and off using external control inputs or selected to be on continuously.

There are three options to reset a fuse after the fault has been rectified:

1. All power removed from the PSU including the battery, then reinstated.
2. The faulty circuit removed and reinstated.
3. The faulty output switched off using the switching control inputs for a minimum of 10 seconds and then switched on again.

Any output with a fuse fault will be indicated by the red Fuse Fault (FF) indicator and the associated output green OK LED will be extinguished.

The outputs are transient protected by a snubbing capacitor and Transient Voltage Suppressor (TVS) diodes. This protection allows the PSU to be used with highly inductive door strikes and magnetic door closers.

The outputs can be connected in parallel to provide more current per circuit, see table below:

Number of Fuses	Output Current
1	1A
2	2A
3	3A

When individual outputs are connected in parallel, they must be selected for the same group, see below:

Switched Groups

There is one set of jumper selection pins per output. The outputs can be selected into three groups, switched group1, switched group2 and un-switched (ON). The selection is done using a three-position jumper as shown below, the jumper is adjacent to the output it controls:

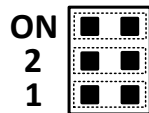

Only one jumper can be used per output and the jumper must be fitted otherwise the relevant output will be permanently OFF. If the ON jumper position is fitted, then the output will be un-switched and permanently ON. The jumper must be fitted in the horizontal position as shown.

The outputs can then be controlled by the SW1, SW2 and All control inputs. When the INV jumper is removed, the relevant outputs will be switched OFF when a positive voltage is applied to the control inputs. With the INV jumper fitted, then the relevant outputs will be switched OFF when 0V is applied to the control inputs. Use a wire from output 9 +(positive) to the input marked ALL, SW2 and SW. With the INV jumper on closing these will interrupt power from the outputs With the jumper INV fitted note that all 3 inputs need to be closed to have power to the outputs. The wire links are switched are switched by the fire relay to interrupt power to the locks so that doors open.

For convenience SW1, SW2 and ALL control inputs have been provided where ALL has priority. When the ALL input is active then all the outputs will be switched OFF. The SW1 and SW2 group ON LED indicators are provided for installer information.

If outputs are paralleled to provide extra current, then the outputs must share identical jumper programming to act in concert. Failure to do this will cause unexpected switching results.

On-Board Indications and Fault outputs

Output Indicators

Nine green LEDs positioned adjacent the output terminal blocks indicate the availability of the relevant output. The LEDs will be off either if they are switched off or the fuse has been blown.

Fuse Fault Indicator

The Fuse Fault (FF) red LED will light to indicate if any fuse has blown. If a fuse has blown on an output, and that output has been switched off, the FF LED will then switch off. It should be noted that a blown fuse can only be detected if the relevant output is switched on.

Switched Output Activity Indicators

Two green LEDs marked 1 and 2 adjacent to the switch control inputs, indicate the status of SW1 and SW2 switched groups respectively. This is useful information for the installer to determine how the outputs are jumper link programmed.

AC OK Indicator and AC Fault opto relay

When the green LED is on indicates the incoming AC mains is present. The associated fault relay will be energised when the green LED is on indicating the AC mains is OK and will be off if AC mains is missing.

Battery OK Indicator and AC Fault Relay opto relay

When the green LED is on, indicates that the battery is in a normal condition, when off indicates any of the following battery faults:

1. Battery connection fault
2. Low battery voltage fault
3. High battery impedance fault

The associated fault relay will be energised when the green LED is on indicating the battery power is OK and will be off if a battery fault is present.

PSU OK Indicator and AC Fault opto relay

When the green LED is on, indicates that the PSU is in a normal state, when off indicates any of the following PSU faults:

1. Internal switch mode PSU fault
2. Over-temperature fault
3. Low-voltage power rail fault
4. Over-voltage fault

DATA Indicator

When this yellow LED is flashing, it will indicate that the data path between Slave and Master PSUs is operating.

OK Output

A 2-way polarized connector is provided for a box-front LED indication. The LED will be lit steadily when the system is normal and will flash if any fault is detected.

Battery Charging Output

The battery charging circuit provides a 1A constant current output designed to charge a battery of 24AH or smaller to 80% of its charge capacity within 24 hours. The output is short circuit, overload and reverse polarity protected.

Master/Slave Operation

Two PSUs can be connected in a master slave configuration, where the master will signal any faults in both PSUs. The master will also control all the PSU output switching.

Connecting the PSU's together is simple, an optional 5-Way cable is connected from the MASTER plug to the second PSU, to the SLAVE plug. The PSU with the cable plugged into the MASTER plug assumes control of the two PSUs.