

Dycon D1535 Power Supply
Technical Description
Installation and Operating Manual
12 volt DC 5 Ampere

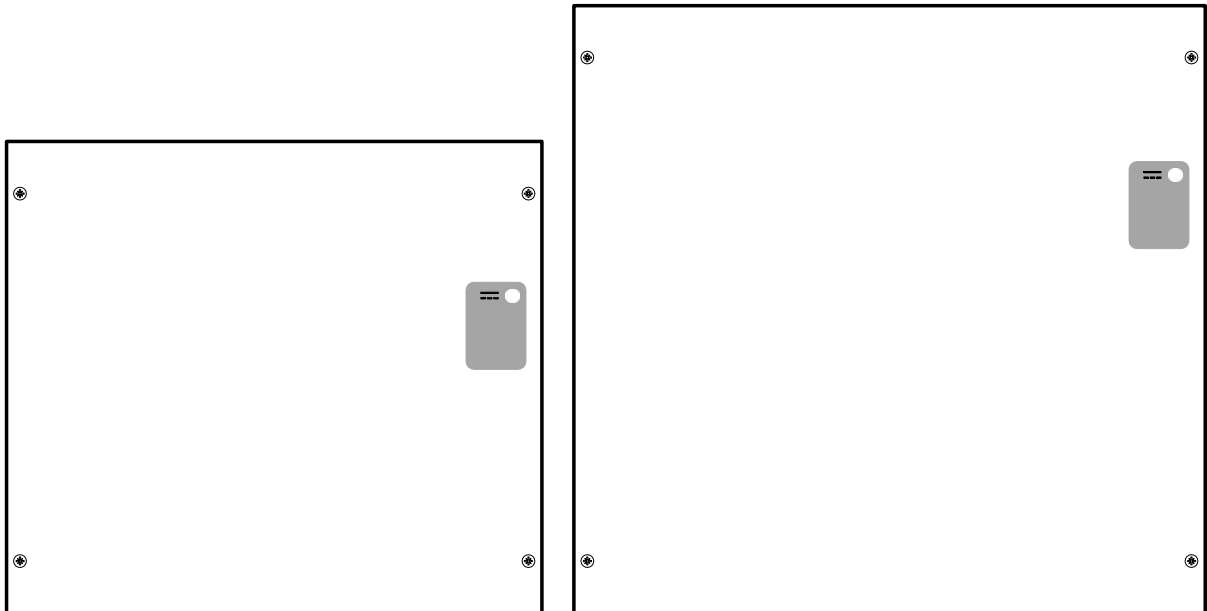

*Scan this QR code to verify
that you are using the latest
version of this manual*

1. General

1.1 Product Range

The D1535-series consists of the following products:

- D1535-P 12VDC 5A power supply module

The power supply module can be supplied in a range of suitable Dycon enclosures:

- EN54-7 Box
- EN54-17 Box
- XB Box
- XLB Box
- XLBD Box
- X Box

1.2 Features

The D1535 power supply is from the Dycon Smart PSU range and is designed to be used for fire alarm control and indicating equipment complying with **EN54-4**, as well as **EN50131-6 grade 1, 2 and 3** for intruder alarm systems.

The power supply provides 5 Ampere at 13.6V with a 12V lead acid battery for standby operation without AC power. The power supply has the following features:

- Microprocessor controlled operation and protection
- On-demand battery charging and load output current sharing
- Automatic output reconnection after short circuit fault
- No user serviceable fuses, outputs protected by electronic E-fuses
- Two independent switched outputs with programmable (jumper selectable) control inputs
- On board or remote temperature sensing for dynamic battery charging
- Three fault outputs, AC Power Fail, Battery Fault, PSU Fault
- Low power opto-relay normally closed fault outputs
- Four status LED's
- Over-voltage output protection and auto disconnect low battery
- Battery-free option selected by a jumper
- Connection for a Dycon PSU Monitor to provide real time measurements and status

The on-demand load sharing capability gives the power supply range exceptional flexibility. This allows rapid large capacity battery charging with either extended standby hold-up duration at light loads, or short high current peak loads where spare output capacity is diverted to battery charging.

2. Electrical and Operational Specifications

SPECIFICATIONS	
AC Input Voltage	230VAC \pm 10%, 50Hz.
Maximum Input Continuous Current	1.5A
Peak inrush current limit	20A maximum.
Recommended Switched Spur Input Fuses	250V T3.15A
Voltage Output AC Present	Minimum 13.4Vdc, Maximum 13.9Vdc.
Voltage Output Standby	Minimum 10.5Vdc, 12 Vdc Nominal

SPECIFICATIONS	
Total Continuous Output Current (I _{max.b})	5A
Current output with battery charging (I _{max.a})	5A
Battery Charging Current	On demand. Minimum 0.5 A Maximum 5A
Low Voltage detection thresholds	<11V \pm 2%, low voltage restore, >11.5V \pm 2%.
Battery Circuit Impedance Threshold (R _{i max})	>0.18 Ohm \pm 5%, at a nominal test current of 5A.
Deep Discharge Disconnection Threshold	<10.5V \pm 2%.
Overvoltage Detection Shutdown Threshold	>15V \pm 2%.
Output Monitoring Threshold	Battery charging voltage <2V \pm 2%.
On-Board AC Power Input Fuses	T3.15A
Battery Fuse	PTC, self-resetting, non-replaceable.
Fault Relays	Normally closed, 100mA at 60V. On-Resistance 16 ohms maximum, 1500VRMS Isolation voltage
PSU Standby Current	32mA.
Maximum Ripple Voltage	0.07V peak to peak.
Battery Type	Sealed Lead Acid Gel , YUASA NP7-12F/RETARD, YUASA NP17-12F/RETARD, YUASA NP7-12, YUASA NP17-12I 22 Ampere Ultra cell UCG22-12
Operating Temperature and Humidity Range	-10°C to +40°C, 95% maximum humidity, non-condensing
Minimum Output Current (I _{min})	150mA for D1535
Battery current drawn by power supply without AC supply	Maximum 55mA (Depending on fault output status) typically 30 mA.

3. Compliance

The power supply complies with the following European Directives:

Low Voltage: 2006/95/EC

EMC: 2004/108/EC

WEEE: 2012/19/EU

RoHs: 2011/65/EU

IEC61140: Protection against electric shock – Common aspects for installation and equipment:
Class 1

EN54-4:1997+A1+A2 part4: Power supply Equipment

BS EN50131-6:2017+A1:2021 Alarm systems. Intrusion and hold-up systems. Power Supplies

4. Power Supply Physical Dimensions and Features

4.1 EN54 Box (EN54-7 and EN54-17)

- Overall dimensions including lid are 330mm x 295mm x 90mm for EN54-7 and 394.5mm x 90mm x 379mm for EN54-17

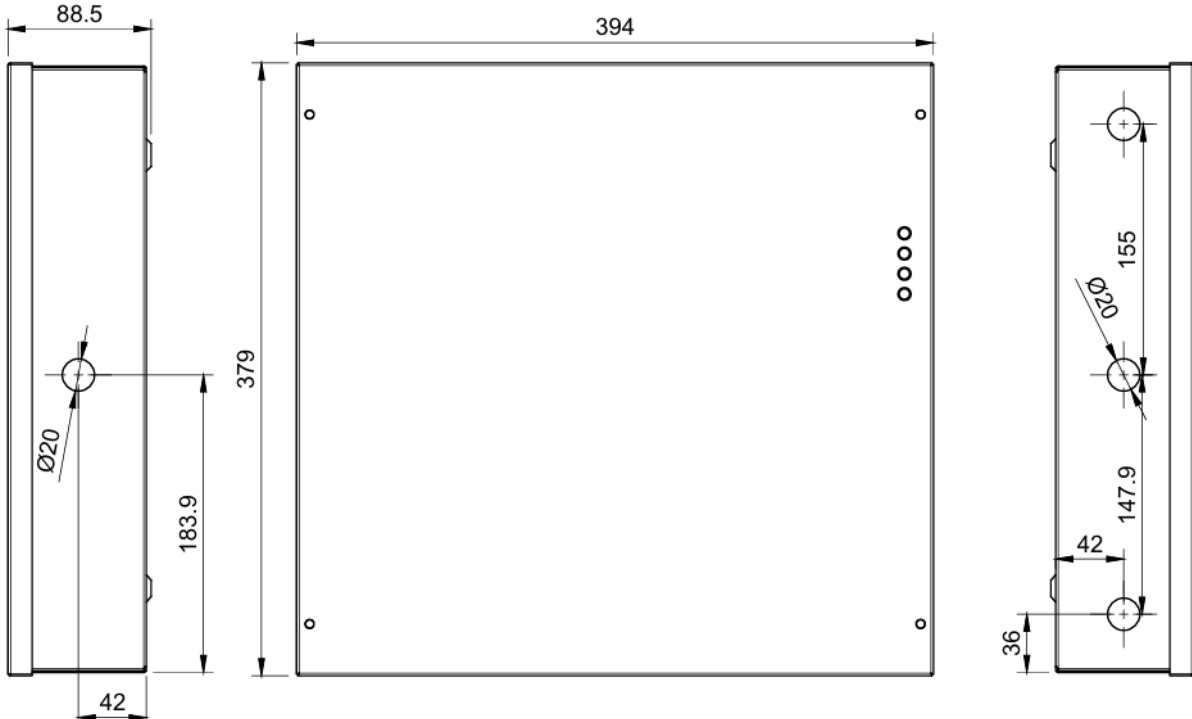
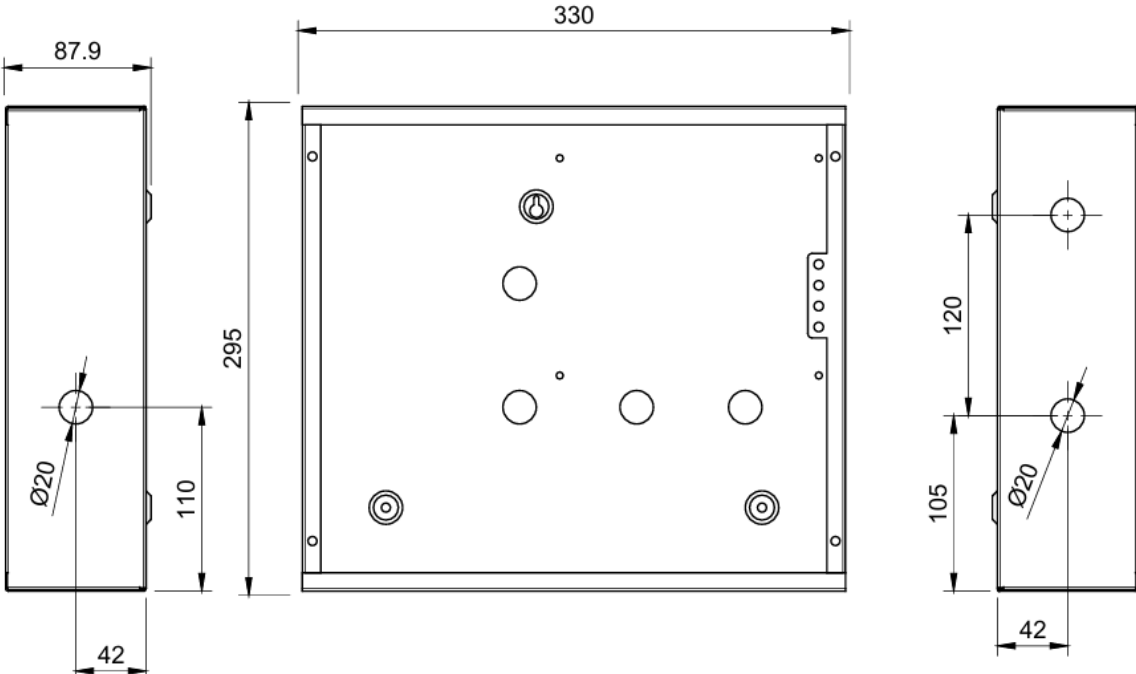

4.2 XLB & XLBD

- Overall dimensions including lid are 413.5mm x 292mm x 90mm for the XLB and 415mm x 292mm x 90mm

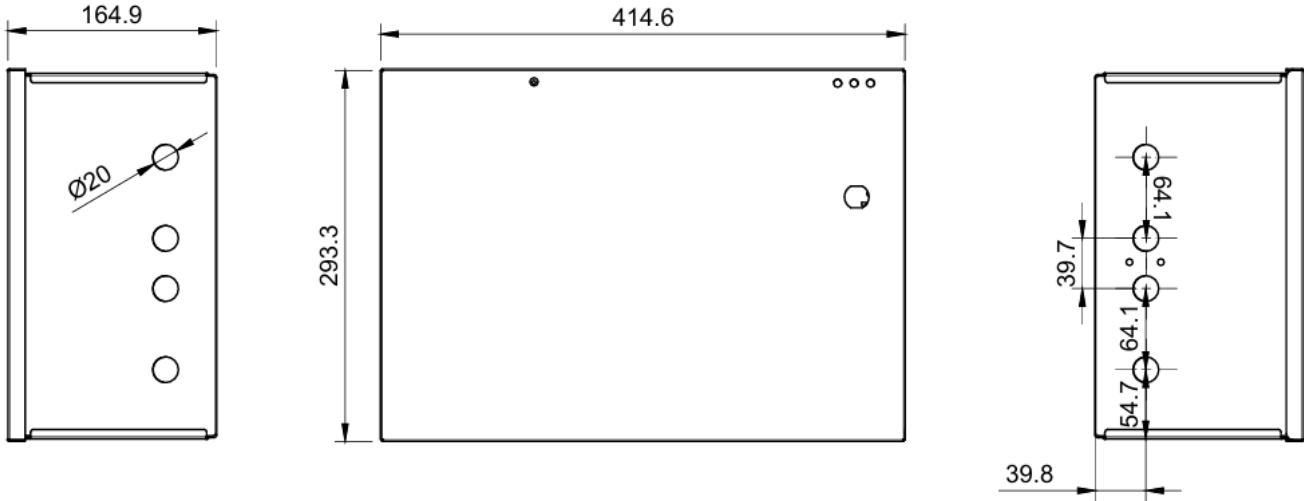
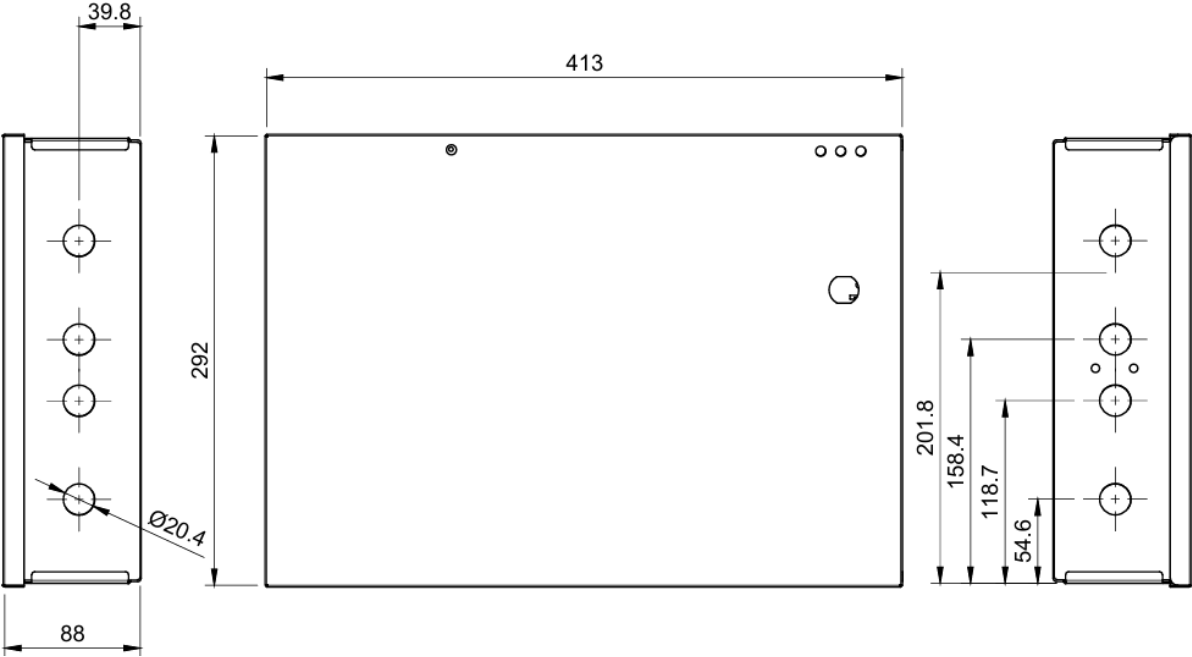

4.3 Printed Circuit Board

The D1535 has the same form, fit and function as the D243X range, the dimensions are identical. The D1535 is shown as below.

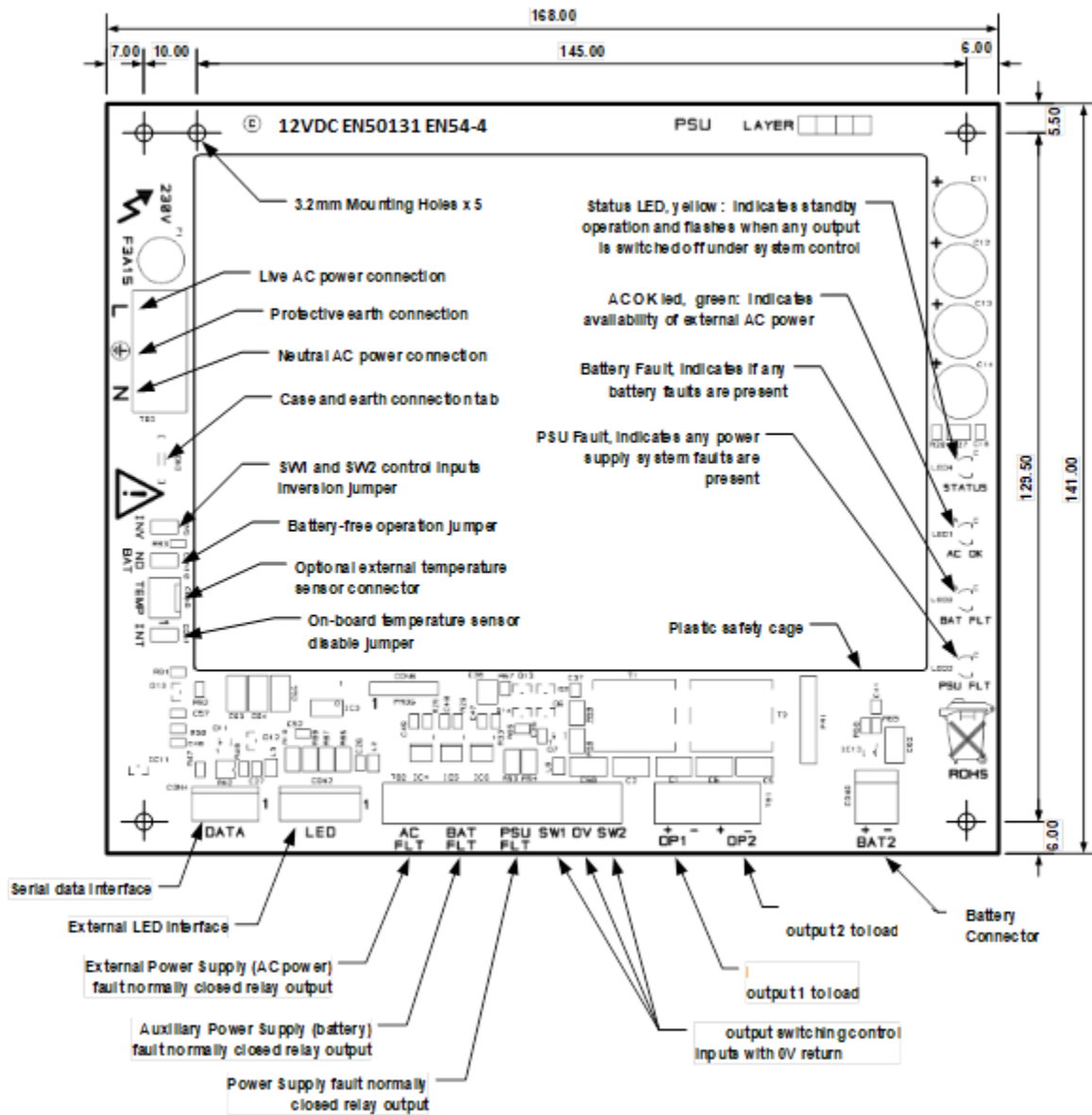

5. Installation and Operation

Warning: Isolate the AC power supply before working on the power supply. Only suitably qualified personnel should install these power supplies and wiring should comply with the latest edition of IEE Wiring Regulations (BS 7671) or local national electrical standards.

5.1 Mounting

The power supplies are designed for indoor use, within the specified operational temperature and humidity limits.

The metal enclosures should be mounted on a solid, flat and dry surface using the three mounting points provided. The screws should have a minimum shank diameter of 5mm (No 11 gauge) and use suitable wall plugs where needed.

When a final siting for the power supply has been decided it is highly recommended that the 20mm knockouts that are going to be used, are removed before fitting the box, use a sharp tap with a hammer and flat bladed screwdriver at the edge of the knockout. Separate knockout holes should be used for AC power entry and low voltage wiring and the wiring kept apart. The knockout holes are designed to accept cable glands.

The power supplies should not be mounted near sources of heat or moisture and should be accessible for ease of fitting heavy batteries.

The printed circuit assembly will have to be removed from the medium sized enclosure before mounting. This is done by pushing the four light pipes towards the lid until they unclip, removing the earth lead by pulling the earth connector off the tab and unscrewing the four board securing screws. The printed circuit assembly can then be removed before mounting.

The keyhole slot at the top of the enclosure may be used as a first fix to hang the unit where the bottom two holes can be marked off when level and then removed for drilling. Using the enclosure directly as a drilling template should not be done as it risks dust damage.

Care should be taken when refitting the board using M3 x 6MM panhead and ensuring they are tight to make good electrical contact with the printed circuit board and the metal base. The light pipes can then be clipped back into place and that they are positioned over the LEDs. The earth cable can then be pushed back on to the connector tab.

5.2 AC Power Connection and Wiring

AC power with a protective earth for Class 1 equipment is to be used with an isolating switched spur using the recommended fuse ratings or a fuse rating of not greater than 5A. The fused switched spur should be fitted as close to the power supply as practicable to allow isolation when the unit is serviced. AC power cable with conductors of a cross-sectional area greater than 0.75mm² should be used.

The AC power cables shall be segregated from the low voltage control wiring and outputs to load. 20mm diameter knockouts on the four sides of the box are provided for cable glands including mineral insulated copper-clad cable. Where a battery is fitted, the knockouts at the bottom of the box will not be available.

To comply with EN54 requirements both AC power and low voltage wiring must use cable glands to meet IP30 enclosure protection standards.

5.3 Jumper Links

Warning: The AC power supply and the batteries must be disconnected before the jumper positions can be changed. Failure to do so can cause damage to the PSU, battery and connected equipment. The power supply must not be used with the INT jumper in the off position without a D2430 external temperature sensor fitted, as this could result in a battery fire or explosion risk.

The NO BAT link must be in the off position to comply with EN54-4 requirements

Three jumper links are provided for configuring the PSU, the “off” position is when the jumper is “parked” on a single pin and the “on” position is when the jumper is placed across two pins:

JUMPER	DEFAULT	OPERATION
INV (Invert inputs)	Off (Not inverted)	When left in the off position the outputs associated with the SW1 and SW2 inputs will be switched on when they are at a logic high. When in the on position the outputs associated with the SW1 and SW inputs will be switched off when they are at a logic high.
NO BAT ¹ (Battery free operation)	Off (Battery monitoring enabled)	With the jumper left in the off position, the PSU will operate as normal with battery standby when AC power is not available. If operation without a battery being fitted is required, then the jumper should be in the on position.
INT ² (Internal/external temperature sensing)	ON (Internal temperature sensing)	When the jumper is fitted the PSU will use the internal on-board temperature sensor, the link must be put into the off position to use an external temperature sensor.

NOTES

1. This jumper can also be used to suppress a battery fault condition until a new battery can be fitted. The jumper disables the battery monitoring only and allows the battery to be charged and provide standby power as normal. **NOTE:** disabling the battery monitoring with a battery fitted will cause an EN54-4 non-compliance.
2. The power supply must not be used with the jumper in the off position without a D2430 external temperature sensor fitted, as this could result in a battery fire or explosion risk.

5.4 LED Display

Four board mounted LEDs are used to provide a status and fault display. The DC power status display indication is brought out to the lid via a light pipe and identified with the label as shown. The other yellow indicators are only visible when the lid is removed:

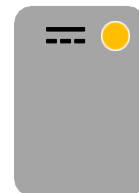

--- STATUS: The yellow LED indicates that DC power is available.

AC OK: The green LED is lit when AC power is available.

BAT FLT: The yellow LED is lit when any battery related faults are detected.

PSU FLT: The yellow LED is lit when any power supply related faults are detected.

5.5 OP1 and OP2

Due to high instantaneous current that can flow under fault conditions, the DC output wire is recommended to be 1mm cross sectional area or greater.

The outputs are individually protected against short circuits. The outputs can be switched using the SW1 and SW2 output control inputs. The outputs are fully protected against switching transients and are suitable for switching highly inductive loads such as door strikes and magnets.

The combined output current of the two outputs must not exceed the power supply ratings.

5.6 SW1 and SW2 Inputs

A wire link between 0v and SW1 and/or 0v and SW2 will switch output 1 and/or 2 on or off. With the INV jumper setting you can select normally open or normally closed to activate or de-activate the output.

The default is normally open and when you put a wire link (for testing) between 0v and SW1 the output will switch off.

For connection to a fire alarm system place the INV jumper in the ON position and connect 0V to the Common (C) and the SW2 to the Normally closed of the fire relay (NC) note needs to be volt free relay. Place a wire link between 0v and SW1 if output 1 is connected to a controller. This configuration cuts power to the locks in case of a fire alarm but keeps power to the controller.

Other connection options:

These inputs can be used to switch on and off their associated outputs. The polarity of these inputs are selected by the INV jumper, with the jumper in the off position the outputs can be switched off when the input is low and when in the on position (inverted) the output can be switched off with a positive input.

The wiring to these inputs shall not be more than 3 meters in length.

The inputs have a 100K pull-up resistor and are 30V tolerant. They are designed to be easily driven by a 5V logic output, relay contacts or open collector transistors, see drive examples below:

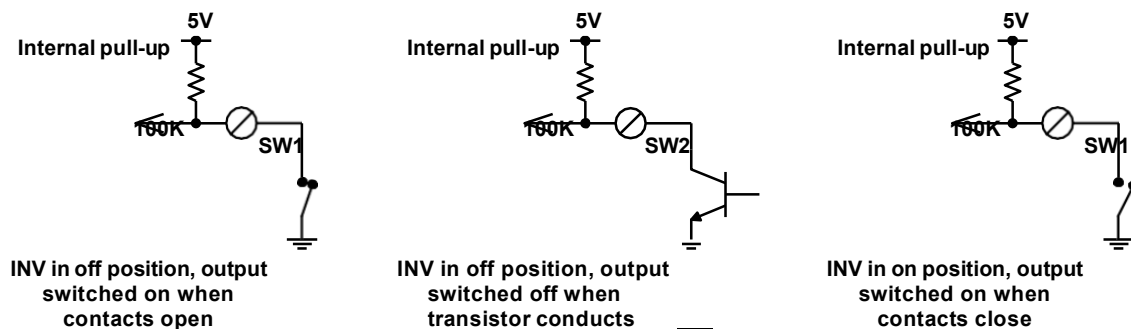

5.7 DATA and LED Interfaces

Data interface is for connection of Dycon PSU monitor which shows real time current, voltage and fault condition on its colour display.

LED Interface is for external LED connections

5.8 Fault Detection and Outputs

Three normally closed relay outputs in no-fault conditions are provided for fault signalling and will open when a fault is detected. The PSU is factory fitted with two wire links as shown below. To comply with EN54 requirements the three separate normally closed fault outputs should be connected in series, so should any one of the fault relays opens in a fault condition, a generic fault condition is signalled.

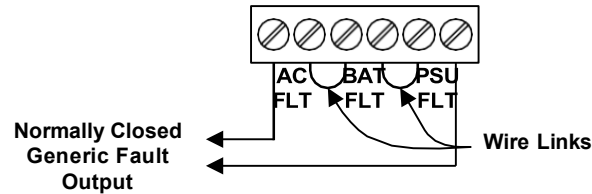

The table below shows the relation between fault and outputs.

FAULT	OUTPUT	DISPLAY	DESCRIPTION
AC power missing	AC Fault	DC Power AC Power	The front panel DC power LED will be on to indicate that DC is available, with or without AC power, The internal AC power LED will be off.
OP1 or OP2 shorted	PSU Fault	PSU	The outputs will automatically retry to restore power every 5 seconds until the short is removed.
Over-voltage ¹	PSU Fault	PSU	If the power supply voltage exceeds 30 volts, both outputs will be switched off and a latched fault generated ² .
Battery connection fault	BAT Fault	Battery	If any of the battery connectors are disconnected a battery fault will be generated.
Battery high ² resistance fault	BAT Fault	Battery	The battery or battery connections are tested every hour and if the resistance is over 0.18ohms, a fault is generated ⁴ .
PSU low voltage	PSU Fault	PSU	If the internal PSU power rail voltage is too low to charge the battery, a fault will be generated ⁵ .
PSU Failure	PSU Fault	PSU	Should the switching power supply fail due to overloading, over-temperature or a component failure, a fault will be generated.
Charging ³ Failure	PSU Fault	PSU	Should the charging circuit fail, then a fault will be generated.
Battery Low Fault	APS ³ Fault	Battery	If any individual battery is left to discharge below 11.5V when the PSU is in standby mode, a fault will be generated.

NOTES

1. Over voltage protection is done at two levels, the first being where the internal power low voltage rail (nominal 12V) is monitored and the second is where the off-line, high voltage side of the switched mode power supply is monitored. Should an off-line fault be found then the high voltage switching circuit will be disabled. In both conditions the power supply should be switched off and the batteries removed for 15 minutes to reset the fault.
2. The battery and connection resistance is tested every hour, except when first powered up. On power-up the battery is tested after 5 minutes to alert the installer to any potential battery condition fault. The fault threshold is approximately 0.18 Ohm.
3. This fault condition is detected by comparing the internal rail voltage to the calculated temperature compensation voltage. If more than 1 volt lower, then a fault will be generated.

5.9 Batteries

Warning: There is a risk of fire and explosion if the wrong battery connection cable is fitted. Care should be taken with polarity when connecting the battery. Used batteries should be disposed of in accordance to the WEEE directive.

A battery of the specified type shall be used, small batteries like 2.2 Ampere are not supported due to the Impedance measurement and will result in a battery fault. A cable harness is provided for individual connection to the board.

The PSU, has as standard, an on-board temperature sensor for accurate temperature compensation to comply with EN54-4 requirements. The size of the battery is dependent on the size of the box, the load current and the amount of standby time required. Available The medium box will house one 7Ah/8Ah/9Ah/10Ah battery and the large box one 17Ah/18Ah/22Ah battery. The battery cable is to be segregated from the incoming AC power supply wiring.

5.9.1 Battery Temperature Remote Sensor Fitting

Optionally, a remote battery temperature sensor is also available. The sensor is plugged into the TEMP 3-way socket and the EXT jumper must be removed to enable the sensor. The sensor is supplied with a 200mm lead The power supply is not to be used with the EXT Jumper link removed without a remote temperature sensor fitted.

5.9.2 Battery Protection

The battery is reverse connection protected and the battery charging output is protected from short circuits.

The battery output is overload protected by a resettable fuse, in addition to the electronic output fuses. If this fuse is tripped then the battery should be disconnected for 5 minutes to allow the fuse to reset.

When in standby mode the battery is switched off when the battery terminal voltage reaches 10V-10.5V to prevent battery deep discharge damage. This fault is normally reset by restoring the AC power supply.

5.10 General Maintenance

Warning: Isolate the AC power supply before removing the power supply lid. Do not touch components or heat sinks as there is risk of electric shock or burn hazard.

The power supply should be regularly inspected by qualified personnel and the following checked:

1. No faults are displayed.
2. Battery terminals checked for corrosion and the terminals are securely tightened.
3. All the connections into the power supply terminal blocks are secure.
4. The battery voltage must be checked. The battery manufacturer's specifications should be consulted when making battery voltage measurements.
5. Battery replacement is recommended after a 5-year service life.
6. Check there are no signs of water or moisture ingress and there is no mechanical damage to the enclosure.
7. Check for signs of overheating on the power supply board and battery cases.
8. Check the voltage outputs, they should be nominally between 13.4V and 13.6V depending on temperature.
9. There are no replaceable input, battery or output fuses. In the event of a fault the power supply board will have to be replaced.



DYCON
power solutions